

Channel Capacity under General Nonuniform Sampling

Yuxin Chen
EE, Stanford University
Email: yxchen@stanford.edu

Yonina C. Eldar
EE, Technion
Email: yonina@ee.technion.ac.il

Andrea J. Goldsmith
EE, Stanford University
Email: andrea@ee.stanford.edu

Abstract—This paper develops the fundamental capacity limits of a sampled analog channel under a sub-Nyquist sampling rate constraint. In particular, we derive the capacity of sampled analog channels over a general class of time-preserving sampling methods including irregular nonuniform sampling. Our results indicate that the optimal sampling structures extract out the set of frequencies that exhibits the highest SNR among all spectral sets of support size equal to the sampling rate. The capacity under sub-Nyquist sampling can be attained through filter-bank sampling, or through a single branch of modulation and filtering followed by uniform sampling. The capacity under sub-Nyquist sampling is a monotone function of the sampling rate. These results indicate that the optimal sampling schemes suppress aliasing, and that employing irregular nonuniform sampling does not provide capacity gain over uniform sampling sets with appropriate preprocessing for a large class of channels.

Index Terms—nonuniform sampling, sampled analog channels, sub-Nyquist sampling

I. INTRODUCTION

Capacity of analog channels along with the capacity-achieving transmission strategies was pioneered by Shannon. These results have provided fundamental insights for modern communication system design. Most Shannon capacity results (e.g. [1], [2]) focus on the analog capacity commensurate with sampling at or above twice the channel bandwidth, which does not explicitly account for the effects upon capacity of sub-Nyquist rate sampling. In practice, however, hardware and power limitations may preclude sampling at the Nyquist rate associated with the channel bandwidth. On the other hand, although the Nyquist sampling rate is necessary for perfect recovery of bandlimited functions, this rate can be excessive when certain signal structures are properly exploited. Inspired by recent “compressive sensing” ideas, sub-Nyquist sampling approaches have been developed to exploit the structure of various classes of input signals with different structures (e.g. [3], [4]).

Although optimal sampling methods have been extensively explored in the sampling literature, they are

typically investigated either under a noiseless setting, or based on statistical reconstruction measures (e.g. mean squared error (MSE)). Berger *et. al.* [5] related MSE-based optimal sampling with capacity for several special channels but did not derive the sampled capacity for more general channels. Our recent work [6] established a new framework that characterized sub-Nyquist sampled channel capacity for a broad class of sampling methods, including filter-bank and modulation-bank sampling [3], [7]. For these sampling methods, we determined optimal sampling structures based on capacity as a metric, illuminated intriguing connections between MIMO channel capacity and capacity of undersampled channels, as well as a new connection between capacity and MSE.

One interesting fact we discovered in this previous work is the non-monotonicity of capacity with sampling rate under filter- and modulation-bank sampling, assuming an equal sampling rate per branch for a given number of branches. This indicates that more sophisticated sampling schemes, adaptive to the sampling rate, are needed to maximize capacity under sub-Nyquist rate constraints, including both uniform and nonuniform sampling. Beurling pioneered the investigation of general nonuniform sampling for bandlimited functions. However, it is unclear which sampling method can best exploit the channel structure, thereby maximizing sampled capacity under a sub-Nyquist sampling rate constraint. Although several classes of sampling methods were shown in [6] to have a closed-form capacity solution, the capacity limit might not exist for general sampling. It remains unknown whether there exists a capacity upper bound over a general class of sub-Nyquist sampling systems and, if so, when the bound is achievable.

In this paper, we derive the sub-Nyquist sampled channel capacity for a general class of time-preserving nonuniform sampling methods. We demonstrate that the fundamental limit can be achieved through filter-bank sampling with varied sampling rate at different branches, or a single branch of modulation and filtering followed by uniform sampling. Our results indicate that irregular

sampling sets, which are more complicated to realize in hardware, do not provide capacity increase compared with regular uniform sampling sets for a broad class of channels. Furthermore, we demonstrate that the optimal sampling schemes suppress aliasing through filter bank, modulation, or input optimization.

II. SAMPLED CHANNEL CAPACITY

A. System Model

We consider a waveform channel, which is modeled as a linear time-invariant (LTI) filter with impulse response $h(t)$ and frequency response $H(f) = \int_{-\infty}^{\infty} h(t)e^{-j2\pi ft}dt$. The channel output is given by

$$r(t) = h(t) * x(t) + \eta(t), \quad (1)$$

where $x(t)$ is the transmitted signal, and $\eta(t)$ is stationary Gaussian noise with power spectral density $\mathcal{S}_\eta(f)$. We assume throughout that *perfect channel state information* is known at both the transmitter and receiver.

The analog channel output is passed through M ($1 \leq M \leq \infty$) linear preprocessing systems each followed by a pointwise sampler, as illustrated in Fig. 1. The preprocessed output $y_k(t)$ at the k th branch is obtained by applying a linear operator \mathcal{T}_k to $r(t)$, i.e. $y_k(t) = \mathcal{T}_k(r(t))$. The linear operators can be time-varying, and include filtering and modulation as special cases. We define the impulse response $q(t, \tau)$ of a time-varying system as the output seen at time t due to an impulse in the input at time τ . The pointwise sampler following the preprocessor can be *nonuniform*. The preprocessed output $y_k(t)$ is sampled at times $t_{k,n}$ ($n \in \mathbb{Z}$), yielding a sequence $y_k[n] = y_k(t_{k,n})$. At the k th branch, the *sampling set* is defined by $\Lambda_k := \{t_{k,n} \mid n \in \mathbb{Z}\}$. When $t_{k,n} = nT_s$, Λ_k is said to be uniform with period T_s .

B. Sampling Rate

In general, the sampling set Λ may be irregular. This calls for a generalized definition of the sampling rate. One notion commonly used in sampling theory is the Beurling density [8] as defined below.

Definition 1 (Beurling Density). For a sampling set Λ , the upper and lower Beurling density are defined as

$$\begin{cases} D^+(\Lambda) &= \lim_{r \rightarrow \infty} \sup_{z \in \mathbb{R}} \frac{\text{cardinality}(\Lambda \cap [z, z+r])}{r}, \\ D^-(\Lambda) &= \lim_{r \rightarrow \infty} \inf_{z \in \mathbb{R}} \frac{\text{cardinality}(\Lambda \cap [z, z+r])}{r}. \end{cases}$$

When $D^+(\Lambda) = D^-(\Lambda)$, the sampling set Λ is said to be of uniform Beurling density $D(\Lambda) := D^-(\Lambda)$.

When the sampling set is uniform with period T_s , the Beurling density is $D(\Lambda) = 1/T_s$, which coincides with our conventional definition of the sampling rate.

Given a preprocessed output $y_k(t)$, we can use Beurling density to characterize the sampling rate on $y_k(t)$. However, since the preprocessor might distort the time scale of the input, the resulting ‘‘sampling rate’’ might not make physical sense, as illustrated below.

Example 1 (Compressor). Consider a preprocessor defined by the relation $y(t) = \mathcal{T}(r(t)) = r(Lt)$ with $L \geq 2$ being a positive integer. If we apply a uniform sampling set $\Lambda = \{t_n : t_n = n/f_s\}$ on $y(t)$, then the sampled sequence at a ‘‘sampling rate’’ f_s is given by $y[n] = y(n/f_s) = r(nL/f_s)$, which corresponds to sampling $r(t)$ at rate f_s/L . The compressor effectively time-warps the signal, thus resulting in a mismatch of the time scales between the input and output.

The example of the compressor illustrates that the notion of a given sampling rate may be misleading for systems that exhibit time warping. Hence, our results will focus on sampling that preserves time scales. A class of linear systems that preserves time scales are modulation operators ($y(t) = p(t)x(t), \forall t$), which perform pointwise scaling of the input, and hence do not change the time scale. Another class are periodic systems which includes LTI filtering, and are defined as follows.

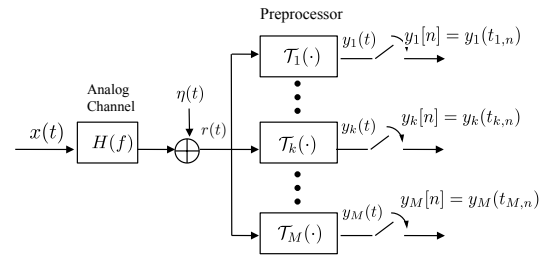

Figure 1. The input $x(t)$ is constrained to $[-T, T]$ and passed through an analog channel and contaminated by noise $\eta(t)$. The analog channel output $r(t)$ is then passed through a linear preprocessing system \mathcal{T} . The preprocessed output $y(t)$ is observed over $[-T, T]$ and sampled on the sampling set $\Lambda = \{t_n \mid n \in \mathbb{Z}\}$.

Definition 2 (Periodic System). A linear preprocessing system is said to be periodic with period T_q if its impulse response $q(t, \tau)$ satisfies

$$q(t, \tau) = q(t + T_q, \tau + T_q), \quad \forall t, \tau \in \mathbb{R}. \quad (2)$$

A more general class of systems that preserve the time scale can be generated through modulation and periodic subsystems. Specifically, we can define a general time-preserving system by connecting a set of modulation or periodic operators in parallel or in serial. This leads to the following definition.

Definition 3 (Time-preserving System). Given an index set \mathcal{I} , a preprocessing system $\mathcal{T} : x(t) \mapsto \{y_k(t), k \in \mathcal{I}\}$ is said to be time-preserving if

(1) The system input is passed through $|\mathcal{I}|$ (possibly countably many) branches of linear preprocessors, yielding a set of analog outputs $\{y_k(t) \mid k \in \mathcal{I}\}$.

(2) In each branch, the preprocessor comprises a set of periodic or modulation operators connected in serial.

With a preprocessing system that preserves the time scale, we can now define the aggregate sampling rate through Beurling density.

Definition 4. A sampling system is said to be time-preserving with sampling rate f_s if

(1) Its preprocessing system \mathcal{T} is time-preserving.

(2) The preprocessed output $y_k(t)$ is sampled by a sampling set $\Lambda_k = \{t_{l,k} \mid l \in \mathbb{Z}\}$ with a uniform Beurling density $f_{k,s}$, which satisfies $\sum_{k \in \mathcal{I}} f_{k,s} = f_s$.

C. Capacity Definition

Suppose that the transmit signal $x(t)$ is constrained to the time interval $[-T, T]$, and the received signal $y(t)$ is sampled and observed over $[-T, T]$. For a given sampling system \mathcal{P} that consists of a preprocessor \mathcal{T} and a sampling set Λ , and a given time duration T , the capacity $C_T^{\mathcal{P}}(f_s, P)$ is defined as

$$C_T^{\mathcal{P}}(f_s, P) = \max_{p(x)} \frac{1}{2T} I \left(x([-T, T]), \{y[n]\}_{[-T, T]} \right)$$

subject to a power constraint $\mathbb{E}(\frac{1}{2T} \int_{-T}^T |x(t)|^2 dt) \leq P$. Here, $\{y[t_n]\}_{[-T, T]}$ denotes the set of samples obtained within time $[-T, T]$. The sub-Nyquist sampled channel capacity for the given system can be studied by taking the limit as $T \rightarrow \infty$. It was shown in [6] that $\lim_{T \rightarrow \infty} C_T^{\mathcal{P}}(f_s, P)$ exists for a broad class of sampling methods. We caution, however, that the existence of the limit is not guaranteed for all sampling methods, e.g. the limit might not exist for an irregular sampling set. The capacity and an upper bound under general nonuniform sampling is defined as follows.

Definition 5. (1) $C^{\mathcal{P}}(P)$ is said to be the *capacity* of a given sampled analog channel if $\lim_{T \rightarrow \infty} C_T^{\mathcal{P}}(f_s, P)$ exists and $C^{\mathcal{P}}(f_s, P) = \lim_{T \rightarrow \infty} C_T^{\mathcal{P}}(f_s, P)$;

(2) $C_u^{\mathcal{P}}(P)$ is said to be a *capacity upper bound* of the sampled channel if $C_u^{\mathcal{P}}(f_s, P) \geq \limsup_{T \rightarrow \infty} C_T^{\mathcal{P}}(f_s, P)$.

The above capacity is defined for a specific sampling system. Another metric of interest is the maximum data rate for all sampling schemes within a general class of nonuniform sampling systems. This motivates us to

define the sub-Nyquist sampled channel capacity for the class of linear time-preserving systems as follows.

Definition 6 (Sampled Capacity under Time-preserving Linear Sampling). (1) $C(f_s, P)$ is said to be the *sampled capacity* of an analog channel under time-preserving linear sampling for a given sampling rate f_s if $C(f_s, P) = \sup_{\mathcal{P}} C^{\mathcal{P}}(f_s, P)$;

(2) $C_u(P)$ is said to be a *capacity upper bound* of the sampled channel under this sampling if $C_u(f_s, P) \geq \sup_{\mathcal{P}} \limsup_{T \rightarrow \infty} C_T^{\mathcal{P}}(f_s, P)$.

Here, the supremum on \mathcal{P} is over all time-preserving linear sampling systems.

III. CAPACITY ANALYSIS

A. An Upper Bound on Sampled Channel Capacity

A time-preserving sampling system preserves the time scale of the signal, and hence does not compress or expand the frequency response. We now determine an upper limit on the sampled channel capacity for this class of general nonuniform sampling systems.

Theorem 1 (Converse). Consider a time-preserving sampling system with sampling rate f_s . Suppose that the output impulse response of the sampled channel is of finite duration, and that there exists a frequency set B_m that satisfies $\mu(B_m) = f_s$ and

$$\int_{f \in B_m} \frac{|H(f)|^2}{\mathcal{S}_\eta(f)} df = \sup_{B: \mu(B) = f_s} \int_{f \in B} \frac{|H(f)|^2}{\mathcal{S}_\eta(f)} df,$$

where $\mu(\cdot)$ denotes the Lebesgue measure. Then the sampled channel capacity is upper bounded by

$$C_u(f_s, P) = \int_{f \in B_m} \frac{1}{2} \left[\log \left(\nu \frac{|H(f)|^2}{\mathcal{S}_\eta(f)} \right) \right]^+ df, \quad (3)$$

where $[x]^+ \triangleq \max(x, 0)$ and ν satisfies

$$\int_{f \in B_m} \left[\nu - \frac{|H(f)|^2}{\mathcal{S}_\eta(f)} \right]^+ df = P. \quad (4)$$

In other words, the upper limit is equivalent to the maximum capacity of a channel whose spectral occupancy is no larger than f_s . The above result basically implies that even if we allow for more complex irregular sampling sets, the sampled capacity cannot exceed the one commensurate with the analog capacity when constraining all transmit signals to the interval of bandwidth f_s that experience the highest SNR. Accordingly, the optimal input distribution will lie in this frequency set. This theorem also indicates that the capacity is attained when aliasing is suppressed by the sampling structure,

as will be seen later in our capacity-achieving scheme. When the optimal frequency interval B_m is selected, a water filling power allocation strategy is performed over the spectral domain with water level ν .

This theorem can be approximately interpreted based on a Fourier domain analysis. The Fourier transform of the analog channel output is given by $H(f)X(f)+N(f)$, where $X(f)$ and $N(f)$ denote, respectively, the Fourier response of $x(t)$ and $\eta(t)$. This output is passed through the sampling system to yield a sequence at a rate f_s , which can be further mapped to the space of bandlimited functions $\mathcal{L}_2(-f_s/2, f_s/2)$ through linear mapping without frequency warping. The whitening operation for the noise component, combined with the sampling system operator, forms an orthonormal mapping from $\mathcal{L}_2(-\infty, \infty)$ to $\mathcal{L}_2(-f_s/2, f_s/2)$. The optimal orthonormal mapping that maximizes SNR is to extract out a frequency set B_m of size f_s that contains the frequency components with the highest SNR, which leads to the capacity upper bound (3).

The outline of the proof of Theorem 1 is sketched below. We start from the capacity of periodic sampling whose sampled channel capacity exists, and then derive the upper bound through finite-duration approximation of the true channels. Details can be found in [9].

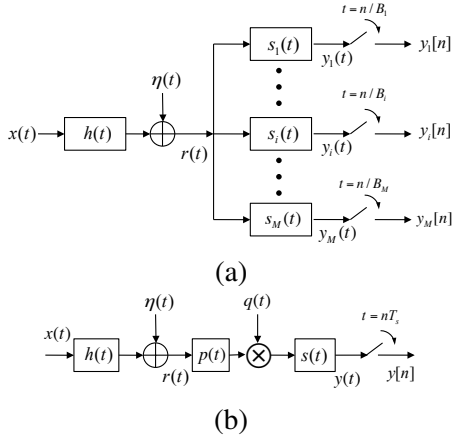

Figure 2. (a) Filter-bank sampling: each branch filters out a frequency interval of bandwidth B_k , and samples it with rate $f_{k,s} = B_k$; (b) A single branch of modulation and filtering: the channel output is prefiltered by a filter with impulse response $p(t)$, modulated by a sequence $q(t)$, post-filtered by another filter of impulse response $s(t)$, and finally sampled uniformly at a rate f_s .

Suppose first that the whole sampling system is periodic, where the impulse response $q(t, \tau)$ is periodic with period T_q ($f_s T_q \in \mathbb{Z}$) and the sampling set obeys $t_{k+f_s T_q} = t_k + T_q, \forall k \in \mathbb{Z}$. The periodicity of the system guarantees the existence of $\lim_{T \rightarrow \infty} C_T^P$. Specifically, denote by $Q_k(f)$ the Fourier transform

$Q_k(f) := \int_{-\infty}^{\infty} q(t_k, t_k - t) \exp(-j2\pi ft) dt$, and introduce an $f_q T_s \times \infty$ dimensional matrix $\mathbf{F}_q(f)$ and an infinite diagonal square matrix $\mathbf{F}_h(f)$ such that for all $m, l \in \mathbb{Z}$ and $1 \leq k \leq f_q T_s$,

$$(\mathbf{F}_q)_{k,l}(f) := Q_k(f + lf_q), \quad (\mathbf{F}_h)_{l,l}(f) = H(f + lf_q).$$

We can then express in closed form the sampled analog capacity as given in the following theorem.

Theorem 2 (Capacity for Periodic Sampling). *Suppose the sampling system \mathcal{P} is periodic with period $T_q = 1/f_q$ and sampling rate f_s . Assume that $|H(f)Q_k(f)|^2/\mathcal{S}_\eta(f)$ is bounded and satisfies $\int_{-\infty}^{\infty} |H(f)Q_k(f)|^2/\mathcal{S}_\eta(f) < \infty$ for all $1 \leq k \leq f_q T_s$, and define $\mathbf{F}_w = (\mathbf{F}_q \mathbf{F}_q^*)^{-\frac{1}{2}} \mathbf{F}_q \mathbf{F}_h$. Then*

$$C^P(f_s, P) = \frac{1}{2} \int_{-f_q/2}^{f_q/2} \sum_{i=1}^{f_s T_q} [\log(\nu \lambda_i \{\mathbf{F}_w \mathbf{F}_w^*\})]^+ df,$$

where ν is chosen according to the water-filling strategy.

We observe that the capacity of any periodic sampling system cannot exceed the capacity (3).

Now we consider the more general sampling system that might not be periodic. For a given input and output duration $[-T, T]$, the impulse response $h(t, \tau)$ ($|t|, |\tau| \leq T$) can be extended periodically to generate an impulse response of a periodic system. Suppose first that the impulse response is of finite duration, then for sufficiently large T , the sampled capacity C_T can be upper bounded arbitrarily closely by the capacity of the generated periodic system, which are further bounded by the upper limit (3). Since the impulse response is constrained in \mathcal{L}^2 space, the leakage signal between different blocks can be made arbitrarily weak by introducing a guard zone with length $T^{1-\epsilon}$. This shows the full generality of our upper bound.

B. Achievability

For most scenarios of physical interest, the capacity upper bound given in Theorem 1 can be achieved through filter-bank sampling.

Theorem 3 (Achievability). *Suppose that the SNR $|H(f)|^2/\mathcal{S}_\eta(f)$ of the analog channel is continuous and Riemann integrable. Then the maximizing frequency set B_m defined in Theorem 1 can be divided into $B_m = \cup_i B_i \cup D$, where D contains a set of singular points, B_i is a continuous interval, and D and $B_i (i \in \mathbb{N})$ are non-overlapping sets. The upper bound in (3) can be achieved by filter-bank sampling. Specifically, in the k^{th}*

branch, the frequency response of the filter is given by

$$S_k(f) = \begin{cases} 1, & \text{if } f \in B_k, \\ 0, & \text{otherwise,} \end{cases}$$

and the filter is followed by a uniform sampler with sampling rate $\mu(B_k)$.

Since the bandwidth of B_i may be irrational and the system may require an infinite number of filters, the sampling system is in general aperiodic. However, filter-bank sampling with *varied sampling rates* in different branches outperforms all other sampling mechanisms in maximizing capacity.

The optimality of filter-bank sampling immediately leads to another optimal sampling structure. As we have shown in [6], filter-bank sampling can be replaced by a single branch of modulation and filtering as illustrated in Fig. 2, which can approach the capacity arbitrarily closely if the spectral support can be divided into subbands with constant SNR. A channel of physical interest can often be approximated as piecewise constant in this way. Given the maximizing frequency set B_m , we first suppress the frequency components outside B_m using an LTI prefilter. A modulation module is then applied to move all frequency components within B_m to the baseband $[-f_s/2, f_s/2]$. The aliasing effect can be significantly mitigated by appropriate choices of modulation weights for different spectral subbands. We then employ another low-pass filter to suppress out-of-band signals, and sample the output using a pointwise uniform sampler. The optimizing modulation sequence can be found in [6], [9]. Compared with filter-bank sampling, a single branch of modulation and filtering only requires the design of a low-pass filter, a band-pass filter and a multiplication module, which are typically lower complexity to implement than a filter bank.

IV. DISCUSSION

The above analytical results characterize the sampled capacity for a general class of sampling methods. Some properties of the capacity results are as follows.

Monotonicity. It can be seen from (3) that increasing the sampling rate from f_s to \tilde{f}_s requires us to crop out another frequency set \tilde{B}_m of size \tilde{f}_s that has the highest SNRs. The original frequency set B_m we choose must be a subset of \tilde{B}_m , and hence the sampled capacity with rate \tilde{f}_s is no lower than that with rate f_s .

Irregular sampling set. Sampling with irregular sampling sets, while requiring complicated reconstruction techniques [8], does not outperform filter-bank or modulation-bank sampling with regular uniform sampling sets in maximizing achievable data rate.

Alias suppression. Aliasing does not allow a higher capacity to be achieved. The optimal sampling method corresponds to the optimal alias-suppression strategy. This is in contrast to the benefits obtained through scrambling of spectral contents in many sub-Nyquist sampling schemes with unknown signal supports.

Perturbation of sampling set. If the optimal filter-bank or modulation sampling is employed, mild perturbation of post-filtering uniform sampling sets does not degrade the sampled capacity. For example, suppose that a sampling rate \hat{f}_s is used in any branch and the sampling set satisfies $|\hat{t}_n - n/\hat{f}_s| \leq \hat{f}_s/4$. Kaded has shown that $\{\exp(j2\pi\hat{t}_n f) \mid n \in \mathbb{Z}\}$ also forms a Riesz basis of $\mathcal{L}^2(-\hat{f}_s/2, \hat{f}_s/2)$, thereby preserving information integrity. The sampled capacity is invariant under mild perturbation of the sampling sets.

Hardware implementation. When the sampling rate is increased from f_{s1} to f_{s2} , we need only to insert an additional filter bank of overall sampling rate $f_{s2} - f_{s1}$ to select another set of spectral components with bandwidth $f_{s2} - f_{s1}$. The adjustment of the hardware system for filter-bank sampling is incremental with no need to rebuild the whole system from scratch.

ACKNOWLEDGEMENT

This work was supported by the NSF Center for Science of Information, the Interconnect Focus Center of the Semiconductor Research Corporation, and BSF Transformative Science Grant 2010505.

REFERENCES

- [1] R. G. Gallager, *Information theory and reliable communication*. New York: John Wiley & Sons, Inc, 1968.
- [2] M. Medard, "The effect upon channel capacity in wireless comms of perfect and imperfect knowledge of the channel," *IEEE Trans. on Info Theory*, vol. 46, no. 3, pp. 933–946, May, 2000.
- [3] M. Mishali and Y. C. Eldar, "From theory to practice: Sub-Nyquist sampling of sparse wideband analog signals," *IEEE Journal of Selected Topics in Signal Processing*, vol. 4, no. 2, pp. 375–391, Apr. 2010.
- [4] —, "Sub-Nyquist sampling: Bridging theory and practice," *IEEE Signal Proc. Mag.*, vol. 28, no. 6, pp. 98–124, Nov. 2011.
- [5] T. Berger, *Nyquist's Problem in Data Transmission Theory*. Cambridge: PhD dissertation, Harvard University, Dec. 1965.
- [6] Y. Chen, Y. C. Eldar, and A. J. Goldsmith, "Shannon meets Nyquist: capacity limits of sampled analog channels," *submitted to IEEE Transactions on Information Theory*, September 2011. [Online]. Available: <http://arxiv.org/abs/1109.5415>
- [7] A. Papoulis, "Generalized sampling expansion," *IEEE Trans on Circuits and Systems*, vol. 24, no. 11, pp. 652–654, Nov 1977.
- [8] A. Aldroubi and K. Gröchenig, "Nonuniform sampling and reconstruction in shift-invariant spaces," *SIAM Review*, vol. 43, no. 4, pp. 585–620, 2001.
- [9] Y. Chen, Y. C. Eldar, and A. J. Goldsmith, "Channel capacity under sub-nyquist nonuniform sampling," *submitted to IEEE Trans on Information Theory*, April 2012. [Online]. Available: <http://arxiv.org/abs/1204.6049>